

HYDRAULIC CRATE TURNER DUMPER - CTD-H-TP-3000

APPROX WEIGHT: 465.81 lbs.
DOES NOT INCLUDE WEIGHT OF POWER OR PACKAGING!!!

*** ANY ADDITIONS, DELETIONS, OR OMISSIONS MUST BE CORRECTED ON THIS DRAWING AS THIS DRAWING WILL BE CONSIDERED ALL INCLUSIVE ***

ALL GRAPHICS PROVIDED ARE FOR REFERENCE ONLY. IF CERTAIN DIMENSIONS ARE CRITICAL PLEASE VERIFY THOSE DIMENSIONS WITH YOUR SALESPERSON

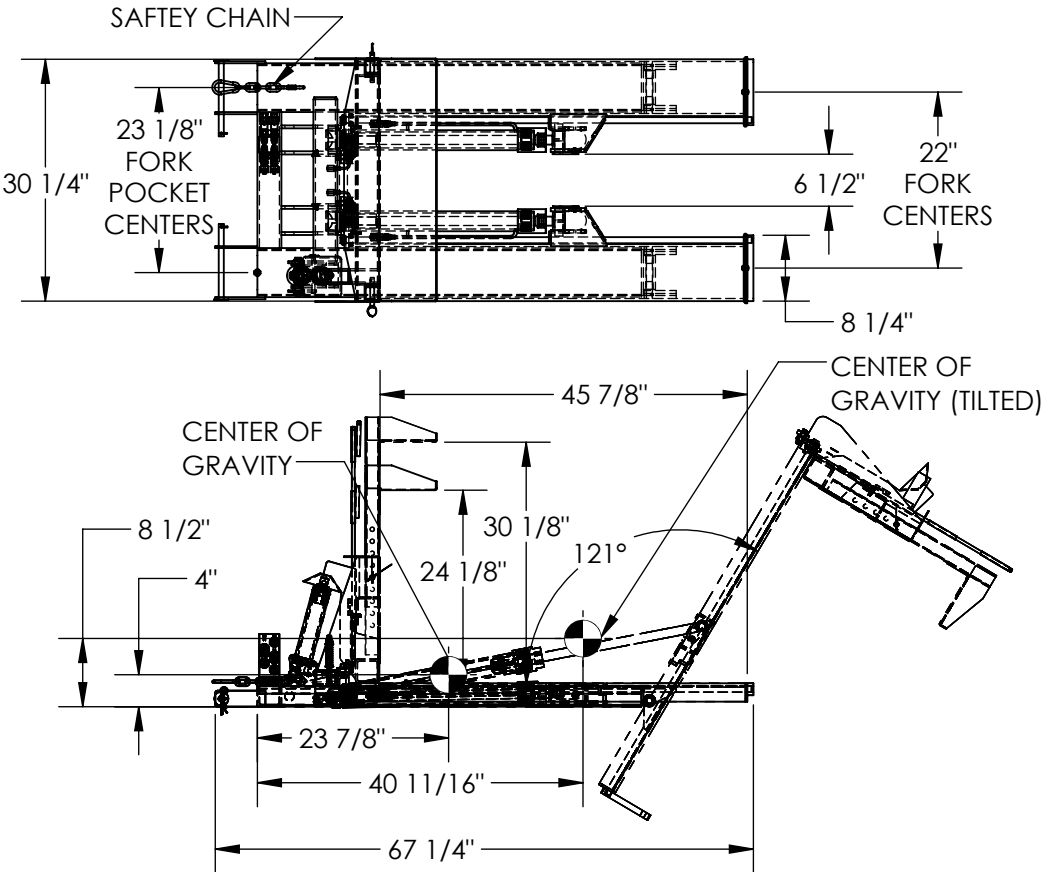

5 1/2"W X 2"H
USABLE FORK POCKETS

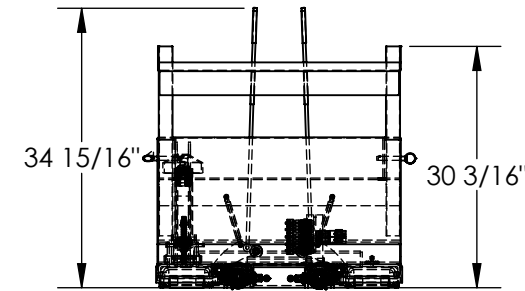
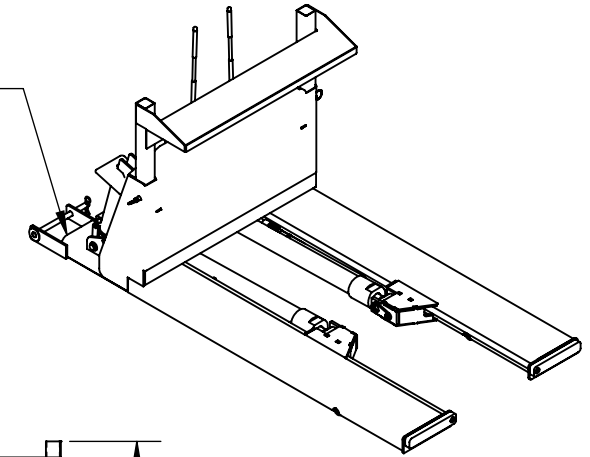

DIMENSION TOLERANCE ± 1/4"

STANDARD FEATURES

MODEL NUMBER IS CTD-H-TP-3000
 OVERALL WIDTH IS 30 1/4"
 OVERALL LENGTH IS 67 1/4"
 USABLE LENGTH IS 45 7/8"
 OVERALL HEIGHT IS 34 15/16"
 USEBLE HEIGHT IS 24 1/8"
 OVERALL TILT IS 121°
 MAX CAPACITY IS 3000 LBS
 USABLE FORK POCKETS: 5 1/2"W X 2"H
 DURABLE LIQUID PAINT YELLOW FINISH
 MINIMUM 2400 PSI, MAXIMUM 3000 PSI FOR
 3000 LBS CAPACITY
 FORK LIFT AUXILIARY CONNECTIONS ARE
 REQUIRED FOR USE
 USABLE HEIGHT INCREMENTS HEIGHT LOCK
 24 1/16", 25 9/16", 27 1/16", 28 9/16", 30 1/16"

APPROX. WEIGHT / LOST LOAD = 465.81
 MINIMUM EFFECTIVE THICKNESS = LESS THAN 1"
 NEVER EXCEED LOAD CENTER
 RATING PER FORKTRUCK
 MANUFACTURERS GUIDELINES.
 DO NOT USE THIS FORK TRUCK
 ATTACHMENT IF LOAD WILL
 EXCEED FORK TRUCK MANUFACTURER'S
 LOAD CENTER RATING

SPECIAL FEATURES

NONE

APPROVAL

I, THE UNDERSIGNED, AGREE THAT THE PRODUCT AS REPRESENTED SATISFIES DESIGN AND DIMENSION REQUIREMENTS. I ALSO ACKNOWLEDGE MY DUTY TO CONFIRM PRODUCT AND INSTALLATION COMPLIANCE WITH ALL APPLICABLE FEDERAL, STATE AND LOCAL REGULATIONS AND STANDARDS.

UNITS REQUIRING APPROVAL DRAWINGS OR MODIFIED ARE NON-RETURNABLE

[] As drawn [] As marked

Signed: _____ Date: _____

Printed Name: _____

LEAD TIME WILL START UPON RECEIPT OF SIGNED APPROVAL DRAWING

DISTRIBUTOR'S NAME:		P.O.#
VESTIL MANUFACTURING		X
DRAWN BY: TAL	DATE: 8/24/2020	W.O.#
REFERENCE: X	SCALE: 1:24	X
QUOTED LEAD TIME: X	QUOTE #	SALES: X
	X	FILE NAME:
		15-007-163